

Line Build Out and Equalization for T1

Digital transmission systems, such as T1 and E1, consist of digital repeaters interconnected by copper lines.

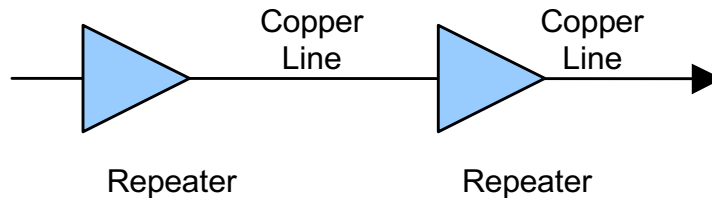

Figure 1 – Digital Transmission System

Signals sent down the copper line will lose strength with distance. The receiver portion of the digital repeaters is designed to accommodate various signal strengths arriving at the input. How much accommodation depends on the technology available at the time when the system was first developed.

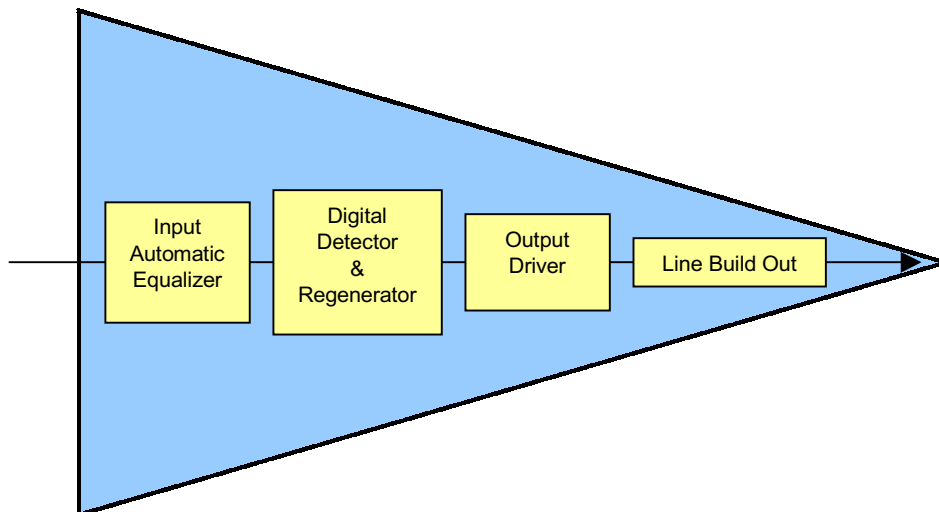

Figure 2 – T1 Digital Repeater Block Diagram

When T1 was first developed, the available technology provided limited range within the automatic equalizer. Thus the installation procedure involves setting the transmitted power to match the expected loss of the cable. First, the installation is divided into two classes, short haul, which is intra-building cabling, and long haul, which is outside plant cabling. Then, within these two classes, further refinements are made. For short haul, the installer is expected to make a rough estimate of the cable length and set the LBO (line build out) to that length. The lengths are 0 to 133 feet, to 266, to 399, to 533, and to 655 feet. Similarly, for long haul, the installer is expected to estimate the line loss and set the equalizer accordingly to 0, 7.5, or 15 dB. The LBO and the Equalizer perform the same function of attenuating the signal before it enters the line. In this way, the signal strength arriving at the next repeater will be within operating limits of the input automatic equalizer.

By the time of the development of E1, some ten years after T1, technology had allowed the input automatic equalizer to accommodate the full range of signal strengths. Thus no length class and no LBO setting are necessary for E1. However, because of legacy T1 systems in place, T1 retained the capability for setting the LBO.

For most modern installations, the input automatic equalizer for T1 is of the same design as for E1. Thus the LBO can be left at long haul 0 dB for these cases. Only when the downstream repeater is suspected of being legacy equipment would LBO settings be necessary. However, the need to use LBO or equalizer involves more than whether legacy equipment is present. The reason is cross talk.

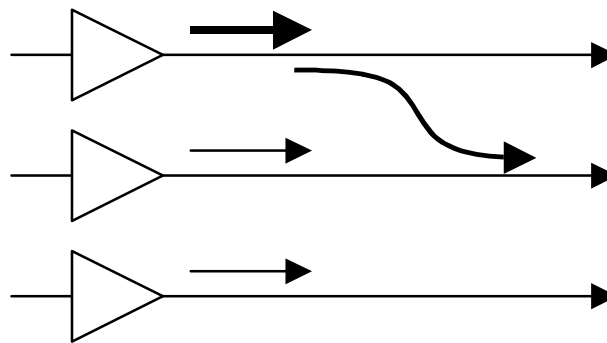

Figure 3 – Cross Talk between Lines.

In the diagram above, if the bottom two repeaters have already invoked the LBO facility, resulting in weaker signals at their output, then the top repeater must also invoke its LBO. If not, as the diagram illustrates, the stronger signal from the top repeater will interfere with the weaker signals at the bottom, known as cross talk.

Therefore, whether to set up the office repeaters with or without LBO depends on the overall office policy rather than on the vintage of the existing repeaters. In most offices, LBO was used in the early days. Once started on this path, because of cross talk, LBO must continue to be used even when the original reason for its use no longer exists.